

Min. afstand til brandmur med isoleret startsektion eller ventileret rør + pyntering

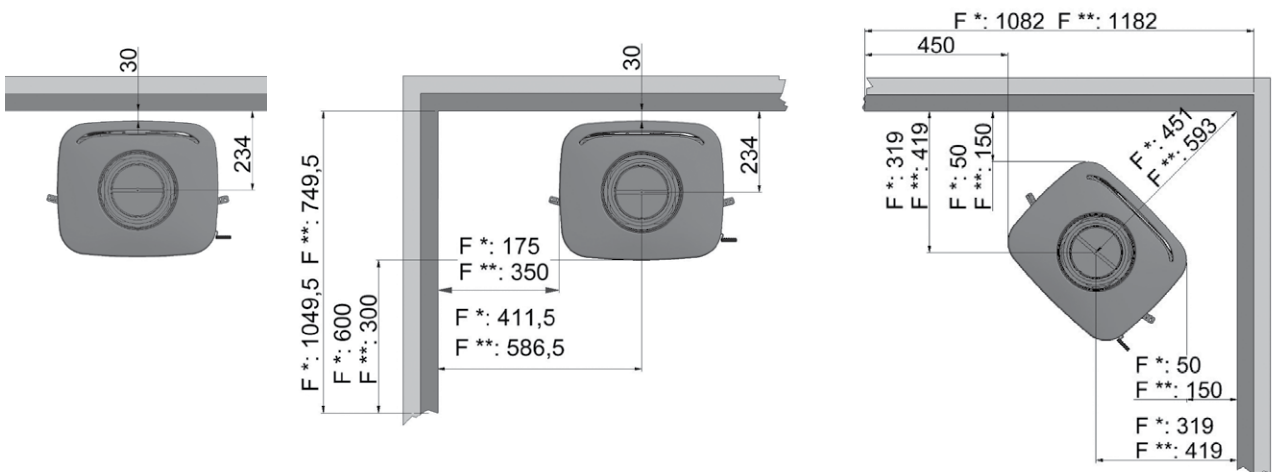

Min. afstand til brændbar væg med isoleret startsektion eller ventileret rør + pyntering

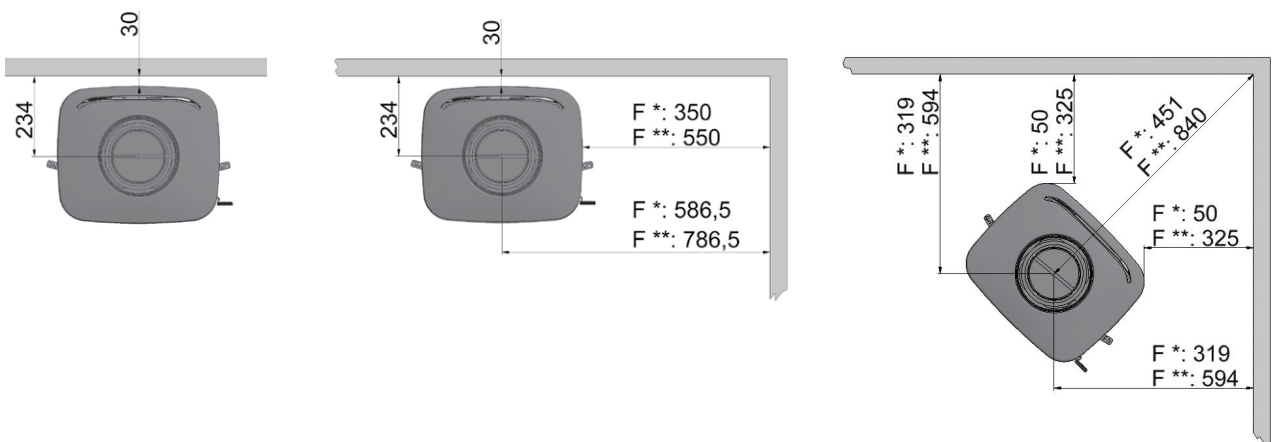

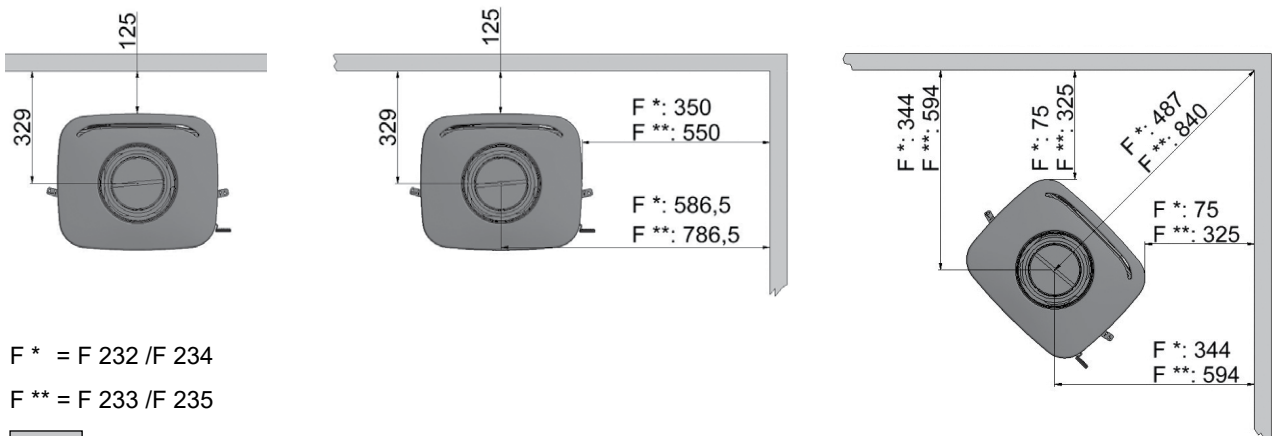

Min. afstand til brændbar væg uden isoleret startsektion



F* = F 232 / F 234

F** = F 233 / F 235

-  Brandbart materiale
-  Brandmur F.eks. 50 mm. Jøtul Firewall